

# 样品承认书



*SAMPLES SPECIFICATION FOR APPROVAL*

*Switching power Supply/开关电源*

客户:

CUSTOMER: \_\_\_\_\_

产品描述:

DESCRIPTION: Input:100-240V ~ 50-60Hz Output: 24VDC7.5A

机种型号:

OUR MODEL NO: MX180Z-24007500

样品编号:

日期:

SAMPLE NO: \_\_\_\_\_

DATE: 2024-08-21

物料编码:

产品颜色/SAMPLE COLOR:

MATERIAL CODE: \_\_\_\_\_

Black

White

APPROVAL SIGNATURE/客户确认

核准/APPROVED BY

审核/CHECKED BY

检测/TESTED BY

Manufacturer/制造商

核准/APPROVED BY

审核/CHECKED BY

制定/MAKER

朱代富

程梦飞

广东明鑫电源技术有限公司

GUANGDONG MINGXIN POWER TECHNOLOGIES CO., LTD.

地址: 中国广东省东莞市常平镇东深路常平段 100 号润丰高新产业园二栋四、五、七楼

Add: Floor 4,5 and 7, Building 2, Runfeng High-tech Park, No.100, shen Road, Changping Town,  
Dongguan City, Guangdong Province, China

Phone: +86-13790582743

Fax: 86-755-88849612

E-mail: ellen@mingxinpower.com

Website: www.mingxinpower.com

**广东明鑫电源技术有限公司**  
**GUANGDONG MINGXIN POWER TECHNOLOGIES CO., LTD.**

版本目录/Rev. List			
版本/Rev.	日期/Date	描述/ Description	制订/Design
A0	2024-08-21	新版本/New Rev.	程梦飞

**目录/Table of contents**

1、描述/ DESCRIPTION.....	3
2、输入特性/INPUT CHARACTERISTICS.....	3
3、输出特性/OUTPUT CHARACTERISTICS.....	4
4、保护功能/PROTECTION FUNCTION.....	5
5、环境要求/ENVIRONMENTAL REQUIREMET.....	5~6
6、安全要求/SAFETY REQUIREMENT.....	6
7、结构参数/MECHANICAL REQUIREMENT.....	7
8、线材/CORD.....	8
9、铭牌附图/LABEL.....	9
10、样品测试报告/ SAMPLES ELECTRICAL TEST REPORT.....	10

**广东明鑫电源技术有限公司**  
GUANGDONG MINGXIN POWER TECHNOLOGIES CO., LTD.

**1、描述/ DESCRIPTION:**

该开关式电源的连续输出功率为 180 W.

The S.M.P.S should be capable of a total continuous DC power output of 180 W atts.

**2、输入特性/INPUT CHARACTERISTICS:**

**2.1 输入电压/Input Voltage:**

额定电压/Rated Voltage: 100-240 Vac

调整范围/Variation Range: 90-264 Vac

**2.2 输入频率/Input Frequency:**

额定频率/ Rated Frequency: 50-60 Hz.

调整频率/Variation Frequency: 47-63 Hz

**2.3 输入电流/Input Current:**

当输入交流电压为额定值的下限电压负载满载时,最大输入交流电流 3 A.

3 Amps max At any input voltage and rated, DC output rated load.

**2.4 浪涌电流/Inrush Current:**

冲击电流峰值在额定电压输入,冷启动(25℃)时,不大于 60A;且在任何负载和输入条件下,不导致永久性损坏或危险.

Impact current peak in the rated voltage input, cold start (25 °C), not more than 60 A; And in any load and input conditions, don't cause permanent damage or dangerous.

**2.5 AC 漏电流/Ac Leakage Current:**

当输入电压 240Vac 时,最大漏电流为 0.25mA./ 0.25mA Max.At240Vac input.

**2.6 Stand-by power consumption ≤ 0.21 Watts.**

待机功耗 ≤ 0.21 W.

**广东明鑫电源技术有限公司**  
**GUANGDONG MINGXIN POWER TECHNOLOGIES CO., LTD.**

**3、输出特性/OUTPUT CHARACTERISTICS:**

**3.1 输出功率/Power output**

电压 Voltage	最小负载 Min. Load	额定负载 Rated. Load	输出功率 Output power
<b>24Vdc</b>	<b>0.01A</b>	<b>7.5A</b>	<b>180W</b>

**3.2 输出特性/Output Characteristics**

模式 Model	电压 Voltage	固定负载 Min. Load	额定负载 Rated. Load	输出电压 Output Range	
				空载电压 (V)	负载电压 (V)
CC 模式	<b>24V</b>	<b>0.01A</b>	<b>7.5A</b>	<b>22.8-25.2</b>	<b>22.8-25.2</b>
CV 模式					

**3.3 纹波和噪音 Ripple and Noise:**

测试条件:在输入 115/230Vac 25°C和输出最小及最大负载时, 使用示波器带宽为 20MHz 连接到适配器的输出端, 同时输出端并联一个 47uF 的电解电容和一个 0.1uF 的瓷片电容.

At 115/230Vac 25°C input and output Min and Max.Load,the ripple and noise are as follows when measure with Max.Bandwidth of 20MHz and Parallel 47uF/0.1uF,crossed connected at testing point.

电压	最大纹波/最大噪音
<u>Voltage</u>	<u>Ripple and Noise(Max.)</u>
<b>+24Vdc</b>	<b>200mV p-p</b>

**3.4 启动延迟时间/Turn on delay time:**

当输入 100Vac 和输出最大负载时,最大启动时间为 3 S.  
3 Second Max.at 100Vac input and output Max.load.

**3.5 保持时间/Hold up time:**

当输入 115Vac 和输出最大负载时,最小保持时间为 5 mS .  
5 mS Min.at 115Vac input and output Max.Load.

**3.6 效率/Efficiency:**

当 115/230Vac 输入电压时, 1/4, 1/2, 3/4 和满载计算平均效率, 最小 88.00%, 适配器满足能效 VI .  
88.00 % Min,At 115/230Vac input voltage,1/4, 1/2, 3/4 and full load calculation average efficiency.Adapter meet efficiency lever VI

**广东明鑫电源技术有限公司**  
**GUANGDONG MINGXIN POWER TECHNOLOGIES CO., LTD.**

**4、保护功能/PROTECTION FUNCTION:**

**4.1 短路电路保护/Short circuit protection:**

该电源供给器在短路解除时能正常工作恢复.

**The power supply will be auto recovered when short circuit faults remove.**

**4.2 过流保护/Over current Protection:**

过流故障排除后,电源将自动恢复正常工作.

**The power supply will be auto recovered when over current faults remove.**

**5、环境要求/ENVIRONMENTAL REQUIREMET:**

**5.1 工作温度/Operating Temperature:**

0℃-25℃,满载,正常工作.

**0℃ to 25℃,Full load, Normal operation.**

**5.2 储藏温度/Storage Temperature:0℃ to 60℃**

带外壳/With package

**5.3 工作湿度/Relative Humidity:**

5%(0℃)~90%(40℃),72 小时,满载,正常工作.

**5%(0℃)~90%(40℃)RH,72Hrs,Full load, Normal operating.**

**5.4 振动/Vibration:**

**1. 测试标准:国际电工电子委员会**

**Operating: IEC 721-3-3 3M3**

**5~9Hz,A=1.5mm**

**加速度(9~200Hz,Acceleration 5m/S<sup>2</sup>)**

**2. 运输/Transportation:**

**IEC 721-3-2 2M2**

**5-9Hz,A=3.5mm**

**9~200Hz,加速度 Acceleration=5m/S<sup>2</sup>**

**200~500Hz,加速度 Acceleration=15m/S<sup>2</sup>**

**3. 轴向振动/Axes,10 cycles per axis.**

在测试过程中不能出现永久性的损坏.

**No permanent damage may occur during testing.**

在电源开启和关闭后,样机能够恢复到最初条件.

**The SAMPLE has to restore to its original situation after power off/on..**

**广东明鑫电源技术有限公司**  
GUANGDONG MINGXIN POWER TECHNOLOGIES CO., LTD.

**5.5 跌落试验/Dropping Packed:**

插墙式跌落高度为 1 米、桌面式跌落高度为 760mm、6 个面各跌一次

1M for wallmount type and 760mm for desktop type as above described, 6 surfaces or one

测试台面是厚 13mm 的夹木板, 离地面高 19-20mm

The horizontal surface Consists of hardwood at least 13mm thick,mounted on two layers of plywood each 19mm to 20mm thick,all supported on a concrete or equivalent non-resilient floor.

**6、安全要求/SAFETY REQUIREMENT:**

**6.1 主熔断器/ MAIN FUSE**

5A250V 保险电阻 Safety Resistor is 5A250V

**6.2 安全: 符合标准 UL62368,GB4943,EN62368 , ; Safety:accord standard with UL62368,GB4943,EN62368 ;**

电磁兼容标准 EMC-Specification : **GB9524/GB17625 ;**

1. 干扰噪声抑制标准 Noise-suppressed acc : **IEC55032 ;**

2.谐波电流的抑制标准 Harmonic current measurement acc : IEC61000-3-2 ;

3.抗静电的承受标准 Immunity to electrostatic discharge(ESD)acc:IEC61000-4-2 ;

空气放电 Air discharge: ±8KV ; 接触放电 Contact discharge: ± 4KV ;

4.抗干扰抑制标准 Immunity to radiated electromagnetic field acc:IEC61000-4-3;

测试条件 Test characteristic: 80-1000MHz; 80%AM(1KHz) 检验条件 Test level 3V/m : **A ;**

5. 抗快速脉冲群标准 Immunity to fast electric transients(burst)acc: **IEC61000-4-4;**

耦合方式 **Coupling On power supplylines** 测试条件 Test Level: **1KV** Assessment criteria 评估标准: **B ;**

6.浪涌测试标准 Surge capability acc: **IEC61000-4-5;**

浪涌电压 Surge voltage: **1KV** Assessment criteria 评估标准: **B ;**

7. 抗骚扰测试 Injected currents susceptibility acc: **IEC61000-4-6;**

测试条件 Test Level: **3V/m** Assessment criteria 评估标准: **A ;**

**6.3 高压/DIELECTRIC STRENGTH Hi-Pot:**

输入对输出/INPUT to OUTPUT :2500Vac/5mA/60S for type test.

(批量生产时/Batch production: 3000Vac/5mA/3S)

1. Between input and output <输入 (2pin 脚短路) ---输出 (正, 负极短路)

2. 电压输出变化曲线 Voltage time graph

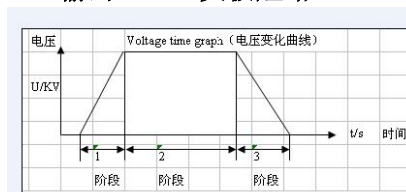

广东明鑫电源技术有限公司  
GUANGDONG MINGXIN POWER TECHNOLOGIES CO., LTD.

6.4 绝缘抗阻/Insulation resistance:

输入对输出/INPUT to OUTPUT  $10M\Omega$  min at 500V DC.

7、结构参数/MECHANICAL REQUIREMENT: (单位: mm)

7.1 外壳/Enclosure:

外壳尺寸: L158.8x W66x H31.61mm(未注明公差 $\pm 1$ mm);

The power supply size: L158.8x W66x H31.61mm;

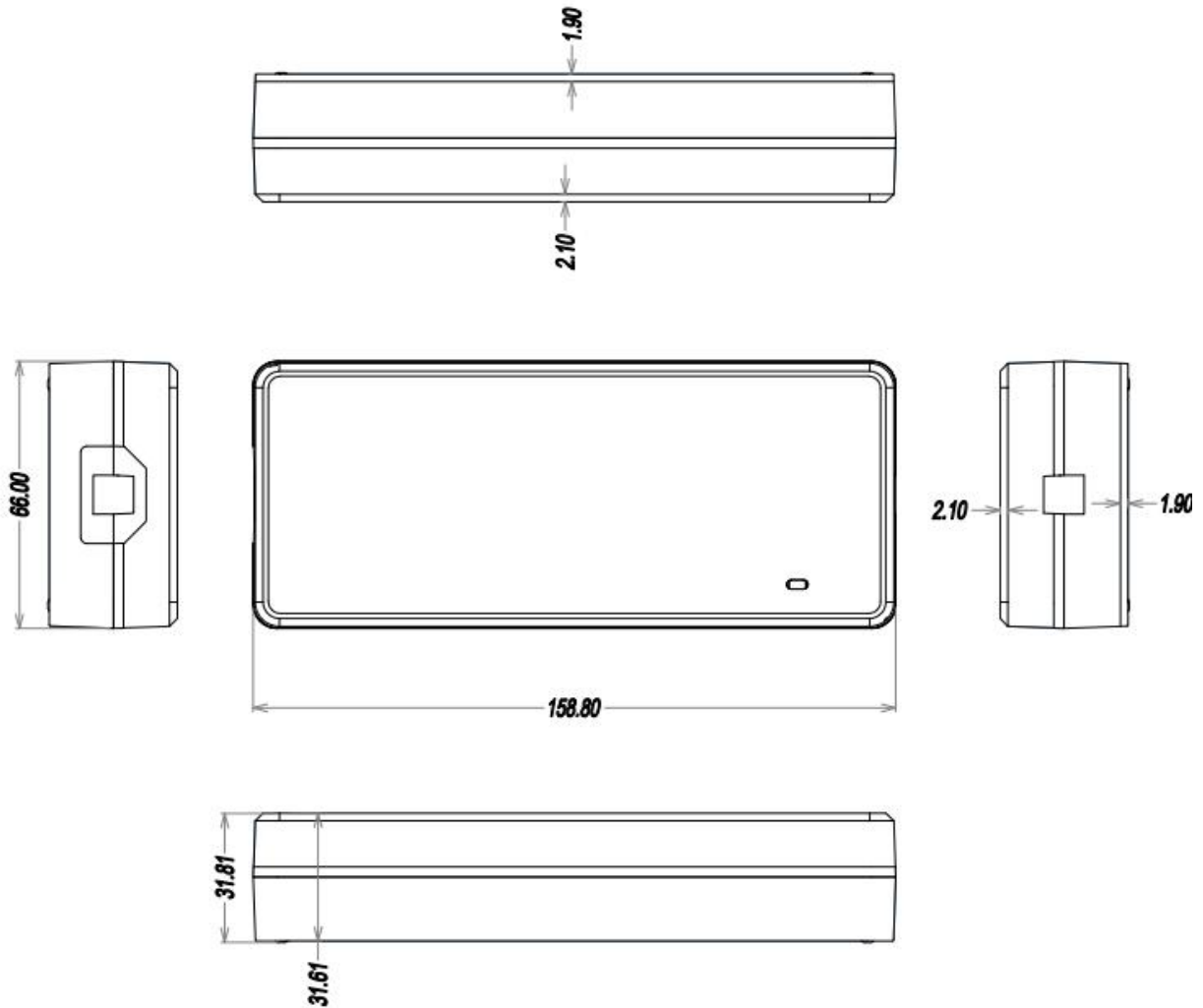

广东明鑫电源技术有限公司  
 GUANGDONG MINGXIN POWER TECHNOLOGIES CO., LTD.

8、线材/CORD: (单位: mm)

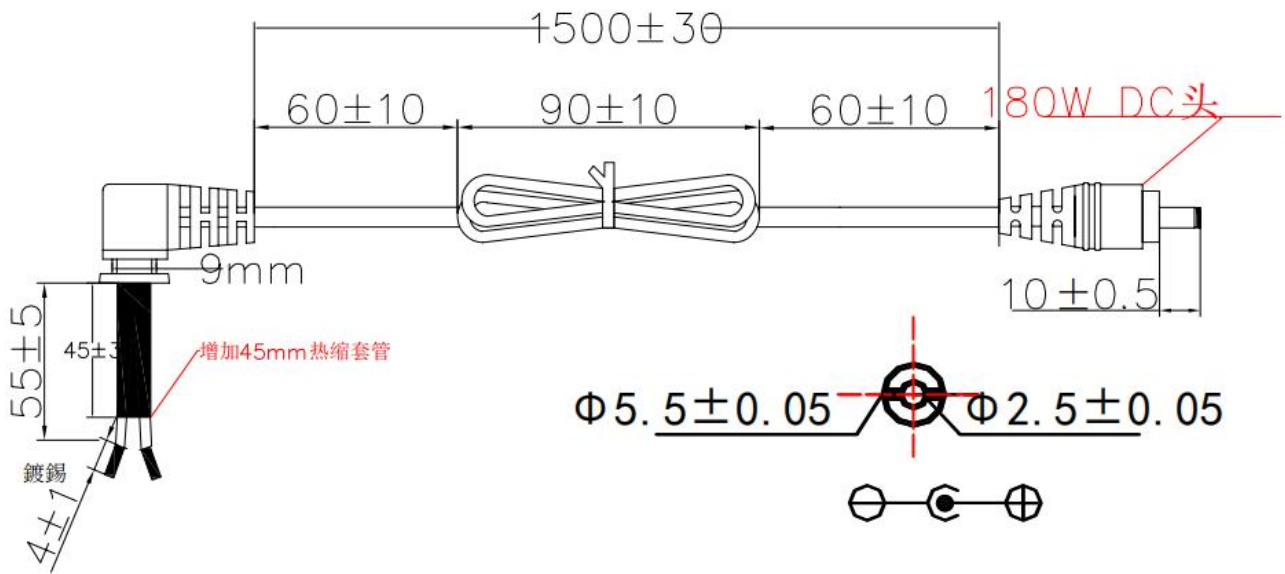

注: DC输出线 UL1185 16AWG 1500mm DC头为  
 5.5x2.5x10mm (过大电流) SR为9\*10mm

单位: mm



广东明鑫电源技术有限公司  
GUANGDONG MINGXIN POWER TECHNOLOGIES CO., LTD.

9、铭牌/LABEL:(单位: mm)

**AC/DC ADAPTER /电源适配器**

MODEL/型号/品番:MX180Z-24007500

INPUT/输入/入力:100-240V~ 50-60Hz 3A

OUTPUT/输出/出力:24.0V $\rightleftharpoons$ 7.5A 180.0W

制造商: 广东明鑫电源技术有限公司

Guangdong Mingxin Power Technologies Co., Ltd.



CONFORMS TO UL STD. 62368-1  
CERTIFIED TO CSA STD. C22.2 No. 62368-1



XXXX



注意: 请在非热带  
雨林气候条件下使用

NOTE: 标签镭射居中

**广东明鑫电源技术有限公司**  
**GUANGDONG MINGXIN POWER TECHNOLOGIES CO., LTD.**

**10、样品测试报告/ SAMPLES ELECTRICAL TEST REPORT :**

Sample form		sample ( 1 )					Spec. Limit	Pass/ Fail	
No	Test Items /测试项目	Unit / 单位	Test condition & result						
			90V	115V	230V	264V			
1	Unload input power 空载输入功率	W	0.07	0.09	0.11	0.13	≤0.21W	PASS	
2	Power factor 功率因数	/	/	0.835	0.997	/	/	/	
3	Rated load input power 额定负载输入功率	W	198.61	198.22	198.39	198.27	≤250W	PASS	
4	Unload output voltage 空载输出电压	V	24.17	24.17	24.17	24.17	22.8-25.2	PASS	
5	Rated load output voltage 额定负载输出电压	A	23.62	23.62	23.62	23.62	22.8-25.2	PASS	
6	Output ripple&noise voltage 输出纹波及噪声电压	mV	/	115	128	/	≤ 200mVp-p	PASS	
7	Over current protection 过流保护点	/	/	11.74	12.21	/	7.5-15	PASS	
8	Average Efficiency 平均效率	%	/	89.73	89.55	/	>88	PASS	
8	Short-circuit Protection 短路保护	W	not damage and with auto recovery function						PASS
Sample form		sample ( 2 )							
1	Unload input power 空载输入功率	W						PASS	
2	Power factor 功率因数	/						/	
3	Rated load input power 额定负载输入功率	W						PASS	
4	Unload output voltage 空载输出电压	V						PASS	
5	Rated load output voltage 额定负载输出电压	V						PASS	
6	Output ripple&noise voltage 输出纹波及噪声电压	mV						PASS	
7	Over current protection 过流保护点	A						PASS	
8	Average Efficiency 平均效率	%						PASS	
sample ( 1 )/sample ( 2 )									
1	Drop test 跌落试验	the Dropping hight of wall mount type is 1M,6 surfaces Dropping respectively						PASS	
2	Drop test 跌落试验	the Dropping hight of wall mount type is 1M,6 surfaces Dropping respectively						PASS	
3	appearance 外观	Content of the NP label is correct,the appearance is clear no spot,scratch color-difference,disconnection and gap						PASS	
4	Burn-in test 老化试验	Input:230Vac/50Hz Full Load 4hrs						PASS	
5	Insualtion test 绝缘测试	INPUT TO OUTPUT:10MΩ min/DC500V,						PASS	
DATE/日期: 2024-08-21		CHECK/审核: 朱代富			APPROVED BY/核准:				
TEST/测试员: 程梦飞									